

PULL PLATE INSTRUCTIONS / MODEL: 40P

FOR USE WITH ECONOMY TYPE EXIT DEVICES



STEP A: INSTALL CYLINDER (SKIP TO STEP B FOR DUMMY PULL PLATE)

1. Use template to mark hole locations on door. If all holes have been drilled or cut, start to install cylinder first.
2. Install rim cylinder through provided cylinder collar, then insert the rim cylinder through hole in pull plate and insert cylinder retaining cup from back side of the pull plate.
3. Fasten rim cylinder assembly using the two (2) break-off screws provided with the rim cylinder.

Note:
The thinner cylinder collar provided with the rim cylinder when it is bought from cylinder supplier in your market that is not available for this trim.

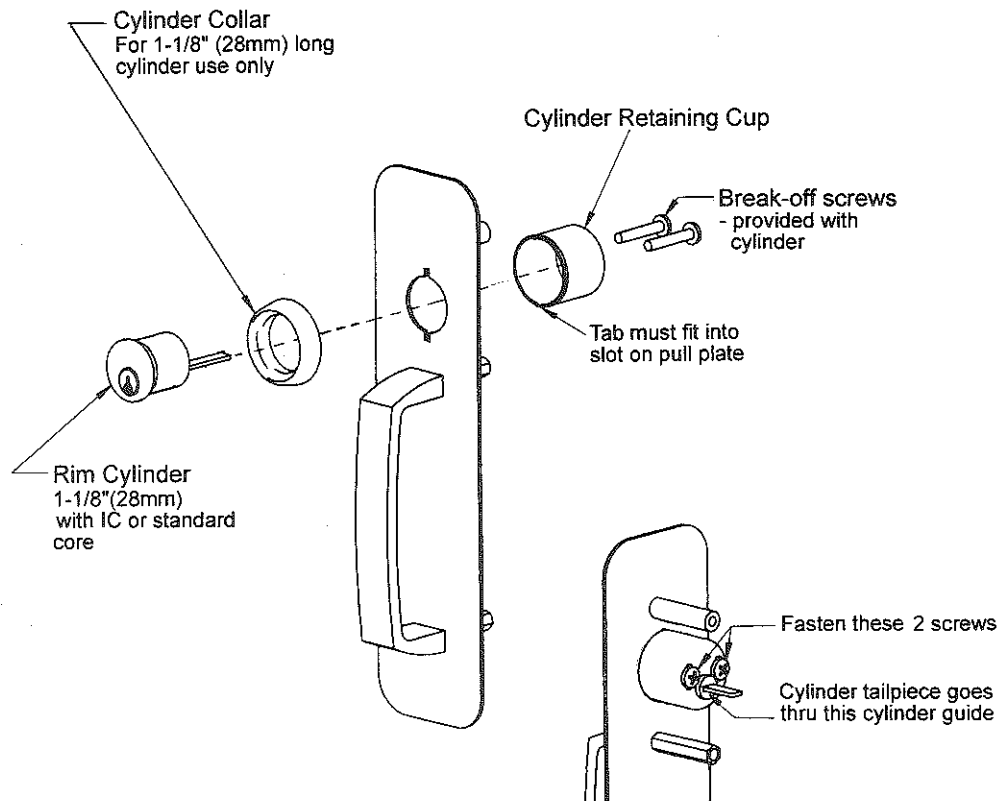

STEP B: INSTALL PULL PLATE

1. Insert pull plate three (3) mounting posts and the cylinder assembly through door.
2. Rim cylinder tailpiece should insert into exit device cam approximately 7/16" long. If it is too long and beyond inside face of door, carefully measure and mark at the closest break-off line. Then use pliers to break off it and get appropriate length.
3. Fasten pull plate and exit device using the supplied three (3) mounting screws.

